

**NOTES:**

1. Concrete Strength: 5000 psi at 28 days.
2. Reinforcement: ASTM A-615 Grade 60.
3. Pins Available: #5 Rebar @ 18" Long.
4. Weight: 240 lbs.

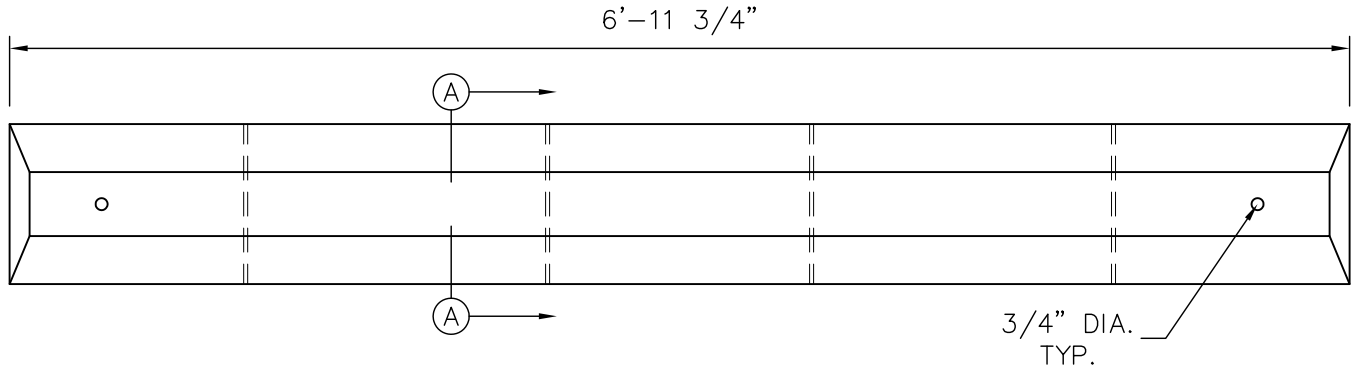

**PLAN VIEW**

SCALE: 1" = 1'-0"

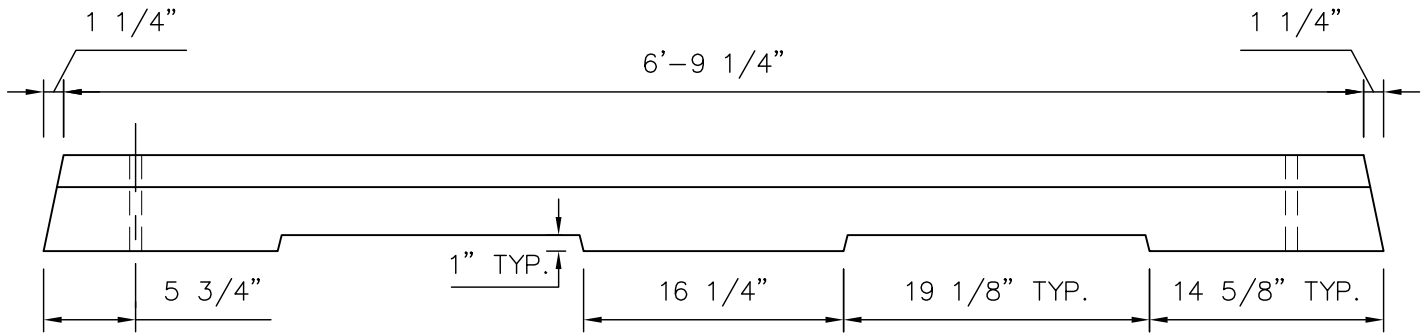

**FRONT VIEW**

SCALE: 1" = 1'-0"

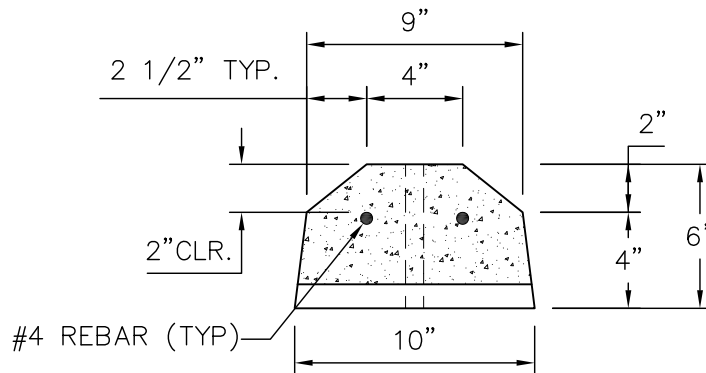

**SECTION VIEW A-A**

SCALE: 1 1/2" = 1'-0"



1-800-638-6884  
www.gillespieprecast.com

**7' Parking Bumper**

DRAWN BY:  
JHP

DWG.:  
1 of 1

SCALE:  
AS NOTED

DATE:  
6/10/16