

PLAN VIEW

NO CONCRETE LIDS,
MUST USE MANHOLE
FRAME AND COVERS
& ADJUSTMENT RINGS

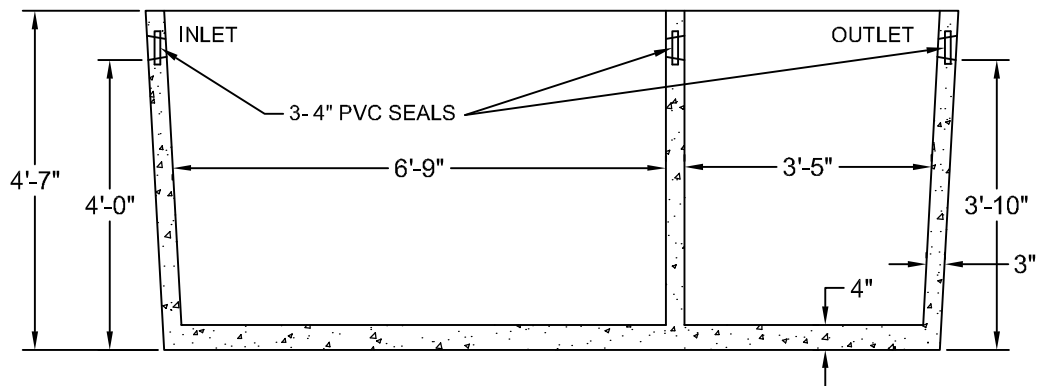
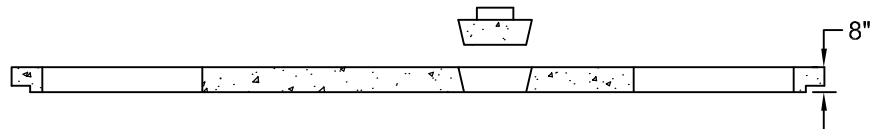

SECTION A-A

1. OVERALL HEIGHT: 5'2"
2. WEIGHT: TANK 9600 lbs.
COVER 6480 lbs.

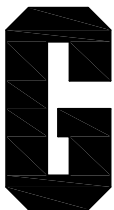

GILLESPIE & SON

CONCRETE PRODUCTS

BOX 450 100 DIXON DR
CHESTERTOWN, MD 21620
1-800-638-6884

**1500 GALLON TOP SEAM
Load Bearing Grease Trap**

DRAWN BY:

J.T.

DATE:

1-22-02

SCALE:

Not to Scale

DWG. #:

1 of 1